



# STEM Careers Project



STEM Careers Project is a joint venture of the Higher Education Commission and Pakistan Atomic Energy Commission, for grooming talented students for careers in Science, Technology; Engineering & Mathematics (STEM).

## Screening TEST: Physics NSTC-19, March 27, 2022

Maximum Marks: 100

Maximum Time: 3 hours

**Check List: Before attempting this question paper please make sure that:**

- Paper contains 10 pages including this page and no page is torn or missing
- Part I consists of 20 multiple choice questions, Part II contain 50 multiple choice questions and Part III contains descriptive questions
- Answer Sheet for MCQs of Part-I & II, and Answer Booklet for Part III

- Part I has 5 multiple-choice questions (MCQs) from each of the subjects of Biology, Computer, Chemistry, Mathematics and Physics. There is a choice between Biology or Computer only, rest of the three subjects are compulsory for every candidate. For Biology or Computer one must blacken the corresponding circle in the answer sheet.
- Part I has 20 MCQs and carries 20 marks. The MCQ portion of the relevant subject of Part II carries 50 Marks. Correct answer carries +1 mark; 1/3 mark will be deducted for each incorrect answer.
- Write your name on the space provided in the Answer Sheet for Part I and Part II. There are four choices (a, b, c, d) corresponding to each multiple-choice question. Blacken one of these choices as shown in the example, which in your opinion is correct. Rough work may be done in the Answer Booklet for Part III by clearly specifying 'Rough Work'.
- The descriptive question(s) of Part III should be solved in the Answer Booklet for Part III. This part carries 30 Marks.
- You are recommended to give frank opinion about the test, including pointing out possible mistakes and legibility problems on the last page of the Answer Booklet. It is meant to motivate you to carefully read the question paper before attempting it. It may be used to discriminate between candidates having similar scores.
- Recommended time for Part I is about 30 minutes and for Parts II and III is about one hour each. The rest of the time is for carefully reading the paper and commenting on it.
- No leaf from the question paper or Answer Booklet is to be torn out as all these must be handed over to the examiner, even if no question has been attempted. Anyone found using unfair means would be disqualified.
- You may use non-programmable calculators.
- No questions will be entertained and no clarification will be made during the test. In case of doubt, please write down your remarks/comments on the last page of the Answer Booklet.
- You must attempt all Parts of the paper. To qualify screening test one should pass both Parts I and the portion of Parts II and III that are relevant to the discipline in which you have applied to appear.
- The term 'estimate' if used in the descriptive portion of Part III means that only an approximate answer is expected from the students. Similarly the term 'sketch' in Part III means drawing a rough graph, which looks like what you might expect from more careful considerations.
- Possession of CELL PHONE or any IMAGING DEVICE in the Examination Hall will be treated as an offence under unfair mean rules.**
- Please put your pen down as soon as you hear the announcement of 'stop writing'.

Students will be short-listed for a one-week Training Camp on the basis of their performance on this Screening Test. Results will be posted on NSTC web page: [www.stem.edu.pk](http://www.stem.edu.pk). Successful candidates will also be informed about their result in about two months after the exam. Please make sure that we have your correct phone/fax number and e-mail address.

## PART-I

### [CANDIDATE MUST ATTEMPT THIS PART]

[It contains 20 MCQs, 5 from each biology/computer, chemistry, mathematics and physics, for selection to the next phase]

Choose either Biology or Computer and must blacken the correct option in the answer sheet.

#### **BIOLOGY**

1. In multicellular organisms, similar cells are organized into groups, called  
a) Organ                      b) Organ system                      c) Tissues                      d) Individual
2. The process by which one diploid cell divides to generate four haploid daughter cells is called  
a) Mitosis                      b) Prophase                      c) Meiosis                      d) Anaphase
3. Red blood cells are also called erythrocytes and transport  
a) nerve impulse                      b) Oxygen                      c) water                      d) food
4. A series of hypothesis supported by the results of many tests is called  
a) Scientific law                      b) Theory                      c) Data                      d) Deduction
5. Artificial cleaning of blood is known as:  
a) Dialysis                      b) Diabetes                      c) Lithotripsy                      d) Both a & b

**OR**

#### **COMPUTER**

1. All the instructions from the users and various softwares are carried out by the \_\_\_\_\_.  
a) ALU                      b) MU                      c) CPU                      d) DVD
2. In a multi-button mouse, one button must be designated as the \_\_\_\_\_ button.  
a) first                      b) left                      c) primary                      d) user
3. Memory that loses its data when power is turned off is considered \_\_\_\_\_ memory.  
a) static                      b) volatile                      c) dynamic                      d) refreshed
4. The more \_\_\_\_\_ a processor has, the more powerful it is.  
a) microns                      b) transistors                      c) connections                      d) Neurons
5. This \_\_\_\_\_ cache holds the most recently used data or instructions.  
a) L1                      b) L2                      c) L3                      d) L4

## CHEMISTRY

6. Which acid is present in vinegar?  
a) Acetic Acid      b) Formic Acid      c) Oxalic Acid      d) Hydro Chloric Acid
7. Which metal exists in fluid form at standard temperature and pressure conditions?  
a) Mercury      b) Bromine      c) Sodium      d) Calcium
8. Which one is not the contribution of Dalton in Chemistry?  
a) Atomic theory      b) Dalton Law      c) Law of multiple proportion      d) Law of conservation of mass
9. What is the empirical formula of Urea?  
a)  $\text{CH}_4\text{ON}_2$       b)  $\text{C}_3\text{H}_4\text{NO}_3$       (c)  $\text{CH}_3\text{NO}_2$       d)  $\text{C}_6\text{H}_5\text{NO}_2$
10. Which vitamin is known as ascorbic acid?  
a) Vitamin A      b) Vitamin B      c) Vitamin C      d) Vitamin D

## MATHEMATICS

11. If  $a * b = a-b+ab$ , then  $2 * 5 + 5 * 2$  is  
a) 14      b) 16      c) 20      d) none of these
12. Which of the fractions below is closest to 1?  
a)  $\frac{8}{7}$       b)  $\frac{9}{10}$       c)  $\frac{10}{11}$       d)  $\frac{11}{10}$
13.  $6^2 + |6| + |-6| - 6^2$  is equal to  
a) -6      b) 0      c) 6      d) 12
14.  $\frac{5^5}{5^4}$   
a) 1      b) 5      c) 25      d) 125
15.  $(a^m)^n =$   
a)  $a^m n$       b)  $a^{m+n}$       c)  $a^{mn}$       d) None of these

## PHYSICS

16. Which is a derived unit?  
a) meter      b) second      c) kilogram      d) newton
17. A boy weighing 500 newtons takes 50. seconds to climb a flight of stairs 18 meters high. His power output vertically is  
a) 9,000 W      b) 4,000 W      c) 1,400 W      d) 180 W
18. Which net charge could be found on an object?  
a)  $+3.2 \times 10^{-18} \text{ C}$       b)  $-1.8 \times 10^{-18} \text{ C}$       c)  $+2.4 \times 10^{-19} \text{ C}$       d)  $-0.80 \times 10^{-19} \text{ C}$
19. Compared to insulators, metals are better conductors of electricity because metals contain more free  
a) protons      b) electrons      c) positive ions      d) negative ions
20. Which two quantities are measured in the same units  
a) momentum and work      b) energy and power  
c) mechanical energy and heat      d) work and power

## PART II – PHYSICS

**21.** Which vector diagram represents the greatest magnitude of displacement for an object?

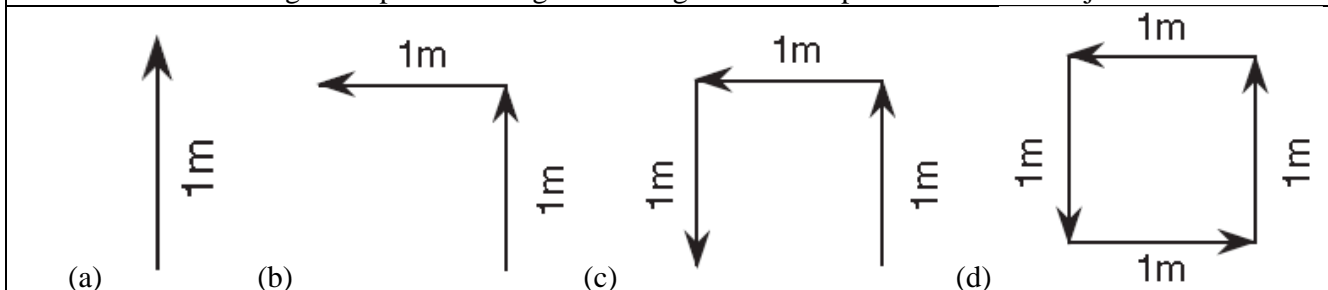

**22.** In the diagram shown on the right, two identical spheres, *A* and *B*, have equal net positive charges. Which arrow best represents the direction of their resultant electric field at point *P*?

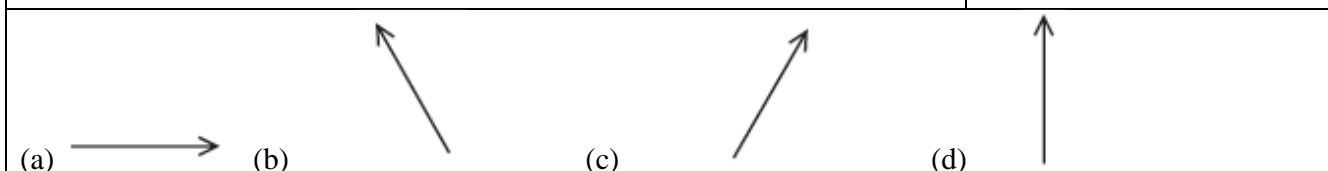
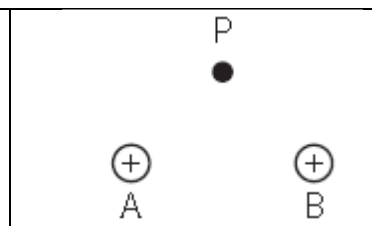

**23.** The graph on the right shows the velocity of a race car moving along a straight line as a function of time. What is the magnitude of the displacement of the car from  $t = 2.0$  seconds to  $t = 4.0$  seconds?

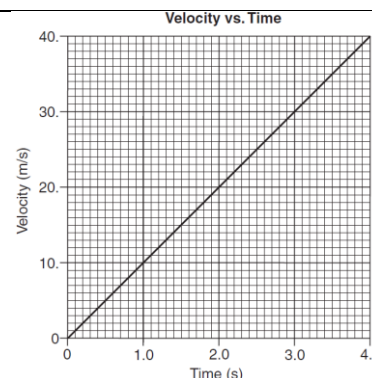

- (a) 20 m                      (b) 40 m                      (c) 60 m                      (d) 80 m

**24.** An archer uses a bow to fire two similar arrows with the same string force. One arrow is fired at an angle of  $60^\circ$  with the horizontal, and the other is fired at an angle of  $45^\circ$  with the horizontal. Compared to the arrow fired at  $60^\circ$ , the arrow fired at  $45^\circ$  has a

- |   |  |
|---|--|
| (a) longer flight time and longer horizontal range  | (b) longer flight time and shorter horizontal range  |
| (c) shorter flight time and longer horizontal range | (d) shorter flight time and shorter horizontal range |

**25.** Which is an acceptable unit for impulse?

- |                             |                                |
|-----------------------------|--------------------------------|
| (a) $\text{N}\cdot\text{m}$ | (b) $\text{J}\cdot\text{s}$    |
| (c) $\text{J/s}$            | (d) $\text{kg}\cdot\text{m/s}$ |

**26.** During a collision, an 84-kilogram driver of a car moving at 24 meters per second is brought to rest by an inflating air bag in 1.2 seconds. The magnitude of the force exerted on the driver by the air bag is approximately.

- (a)  $7.0 \times 10^1 \text{ N}$               (b)  $8.2 \times 10^2 \text{ N}$               (c)  $1.7 \times 10^3 \text{ N}$               (d)  $2.0 \times 10^3 \text{ N}$



36. Identical charges  $A$ ,  $B$ , and  $C$  are located between two oppositely charged parallel plates, as shown in the diagram on the right. The magnitude of the force exerted on the charges by the electric field between the plates is

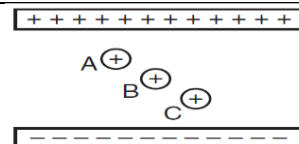

- |   |                                      |
|---|--------------------------------------|
| (a) least on $A$ and greatest on $C$          | (b) greatest on $A$ and least on $C$ |
| (c) the same on $A$ and $C$ , but less on $B$ | (d) the same for $A$ , $B$ , and $C$ |

37. The graph on the right represents the elongation of a spring as a function of the applied force. How much work must be done to stretch the spring 0.40 meter?

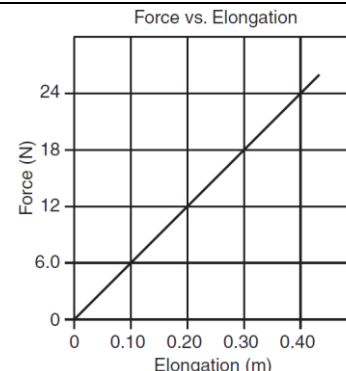

- |           |           |           |          |
|-----------|-----------|-----------|----------|
| (a) 4.8 J | (b) 6.0 J | (c) 9.8 J | (d) 24 J |
|-----------|-----------|-----------|----------|

38. Which circuit diagram shows voltmeter  $V$  and ammeter  $A$  correctly positioned to measure the total potential difference of the circuit and the current through each resistor?

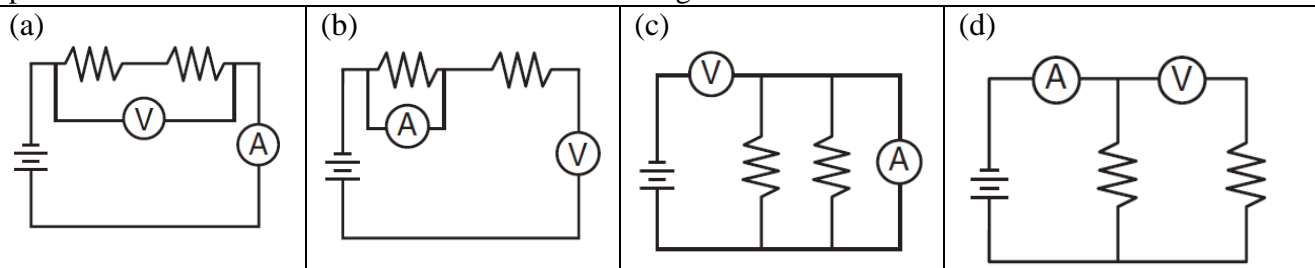

39. The diagram below shows a 4.0-kilogram cart moving to the right and a 6.0-kilogram cart moving to the left on a horizontal frictionless surface. When the two carts collide they lock together. The magnitude of the total momentum of the two-cart system after the collision is

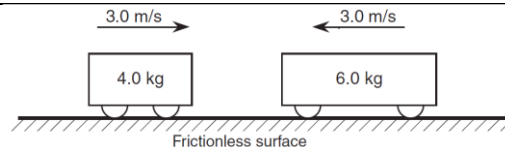

- |                |                |               |               |
|----------------|----------------|---------------|---------------|
| (a) 0.0 kg·m/s | (b) 6.0 kg·m/s | (c) 15 kg·m/s | (d) 30 kg·m/s |
|----------------|----------------|---------------|---------------|

40. In raising an object vertically at a constant speed of 2.0 meters per second, 10 watts of power is developed. The weight of the object is

- |           |           |           |           |
|-----------|-----------|-----------|-----------|
| (a) 5.0 N | (b) 20. N | (c) 40. N | (d) 50. N |
|-----------|-----------|-----------|-----------|

41. A light spring is attached to a heavier spring at one end. A pulse traveling along the light spring is incident on the boundary with the heavier spring. At this boundary, the pulse will be

- |   |   |
|---|---|
| (a) totally reflected   | (b) totally absorbed                            |
| (c) partially reflected and partially transmitted into the heavier spring | (d) totally transmitted into the heavier spring |

42. A wave completes one vibration as it moves a distance of 2 meters at a speed of 20 meters per second. What is the frequency of the wave?

- |          |           |           |           |
|----------|-----------|-----------|-----------|
| (a) 2 Hz | (b) 10 Hz | (c) 20 Hz | (d) 20 Hz |
|----------|-----------|-----------|-----------|

43. Which property determines the direction of the exchange of internal energy between two objects?

- |                 |                   |          |             |
|-----------------|-------------------|----------|-------------|
| (a) temperature | (b) specific heat | (c) mass | (d) density |
|-----------------|-------------------|----------|-------------|

44. What is the speed of light in a medium having an absolute index of refraction of 2.3?

- (a)  $0.77 \times 10^8$  m/s    (b)  $1.3 \times 10^8$  m/s    (c)  $1.5 \times 10^8$  m/s    (d)  $2.3 \times 10^8$  m/s

45. Which graph best represents the relationship between the average molecular kinetic energy ( $\overline{KE}$ ) of an ideal gas and its absolute temperature ( $T$ )?

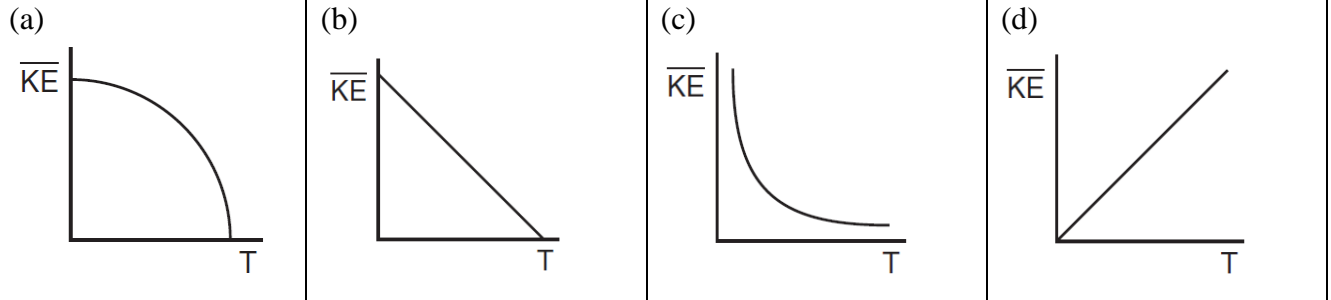

46. The phenomenon by which an incandescent object gives off electrons is known as

- (a) thermionic emission    (b) laser emission    (c) induction    (d) conduction

47. Which characteristics best describe the image produced by a plane mirror?

- (a) real and inverted    (b) real and erect    (c) virtual and inverted    (d) virtual and erect

48. When an object is placed at the focal point of a concave mirror, the mirror produces

- (a) an image that is smaller than the object    (b) an image that is larger than the object  
(c) an image that is the same size as the object    (d) no image of the object

49. Which statement is consistent with Kepler's laws of planetary motion?

- (a) The planets move at a constant speed around the Sun.    (b) The speed of a planet is directly proportional to the radius of the path of motion.  
(c) An imaginary line from a planet to the Sun sweeps out equal areas in equal time intervals.    (d) The more massive the planet, the slower the planet moves around the Sun.

50. The diagram on the right shows an electron  $e$  about to enter the region between the poles of two magnets. Upon entering the region between the poles, the moving electron will experience a magnetic force directed

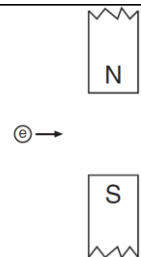

- (a) toward the north pole    (b) toward the south pole    (c) into the page    (d) out of the page

51. An object arrow is placed in front of a concave mirror having center of curvature  $C$  and principal focus  $F$ . Which diagram best shows the location of point  $I$ , the image of the tip of the object arrow?

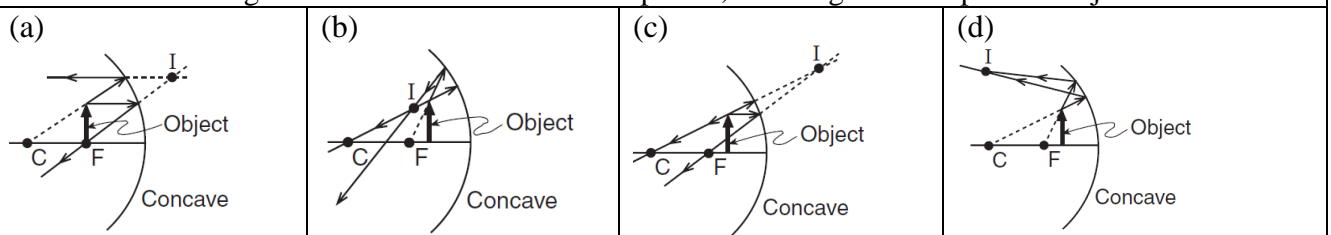

**52.** Two coils of wire are wound around the same permeable core. Coil I has 200 turns and coil II has 3000 turns. Coil I is supplied with 30.0 amperes of alternating current at 90.0 volts. What potential difference is induced in coil II?

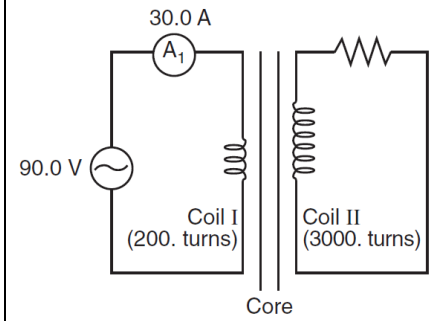

- |            |            |            |            |
|------------|------------|------------|------------|
| (a) 6.00 V | (b) 90.0 V | (c) 1350 V | (d) 2700 V |
|------------|------------|------------|------------|

**53.** A man is standing on a set of bathroom scales, measuring his weight, in an elevator. His weight as shown on the scales is  $W$  before the elevator starts to move. He presses the down button. As the elevator starts to go down, the weight shown on the scales is:

- |                   |                  |                   |   |
|-------------------|------------------|-------------------|---|
| (a) More than $W$ | (b) Equal to $W$ | (c) Less than $W$ | (d) You can't tell without knowing the velocity the lift is moving at |
|-------------------|------------------|-------------------|---|

**54.** The speed of light in vacuum,  $c$ , depends on two fundamental constants, the permeability of free space,  $\mu_0$ , and the permittivity of free space,  $\epsilon_0$ . The speed of light is given by  $c = \frac{1}{\sqrt{\mu_0 \epsilon_0}}$ . The units of  $\epsilon_0$  are  $\text{N}^{-1} \cdot \text{C}^2 \cdot \text{m}^{-2}$ . The units for  $\mu_0$  are:

- |   |  |  |  |
|---|--|--|--|
| (a) $\text{kg}^{-1} \text{m}^{-1} \text{C}^2$ | (b) $\text{kg} \cdot \text{m} \cdot \text{C}^{-2}$ | (c) $\text{kg} \cdot \text{m} \cdot \text{s}^{-4} \cdot \text{C}^{-2}$ | (d) $\text{kg}^{-1} \text{s}^{-3} \text{C}^{-2}$ |
|---|--|--|--|

**55.** Which two graphs represent the motion of an object on which the net force is zero?

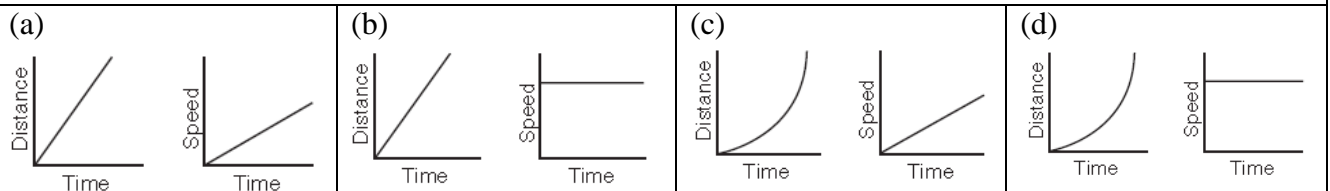

**56.** A large bus and a small car collide and stick together. Which one undergoes the larger change in momentum?

- |              |              |  |   |
|--------------|--------------|--|---|
| (a) The car. | (b) The bus. | (c) The momentum change is the same for both vehicles. | (d) You can't tell without knowing the final velocity of the combined masses. |
|--------------|--------------|--|---|

**57.** An electrostatic force of magnitude  $F$  exists between two metal spheres having identical charge  $q$ . The distance between their centers is  $r$ . Which combination of changes would produce *no* change in the electrostatic force between the spheres?

- |   |   |
|---|---|
| (a) doubling $q$ on one sphere while doubling $r$ | (b) doubling $q$ on both spheres while doubling $r$ |
| (c) doubling $q$ on one sphere while halving $r$  | (d) doubling $q$ on both spheres while halving $r$  |

**58.** A physics student is given three 12-ohm resistors with instructions to create the circuit that would have the lowest possible resistance. The correct circuit would be a

- |   |  |
|---|--|
| (a) series circuit with an equivalent resistance of 36 $\Omega$     | (b) series circuit with an equivalent resistance of 4.0 $\Omega$ . |
| (c) parallel circuit with an equivalent resistance of 36 $\Omega$ . | (d) parallel circuit with an equivalent resistance of 4.0 $\Omega$ |

<b>59.</b> What occurs when light passes from water into flint glass?	
(a) Its speed decreases, its wavelength becomes shorter, and its frequency remains the same.	(b) Its speed decreases, its wavelength becomes shorter, and its frequency increases.
(c) Its speed increases, its wavelength becomes longer, and its frequency remains the same.	(d) Its speed increases, its wavelength becomes longer, and its frequency decreases.

<b>60.</b> Two points on a transverse wave that have the same magnitude of displacement from equilibrium are in phase if the points also have the	
(a) same direction of displacement and the same direction of motion	(b) same direction of displacement and the opposite direction of motion
(c) opposite direction of displacement and the same direction of motion	(d) opposite direction of displacement and the opposite direction of motion

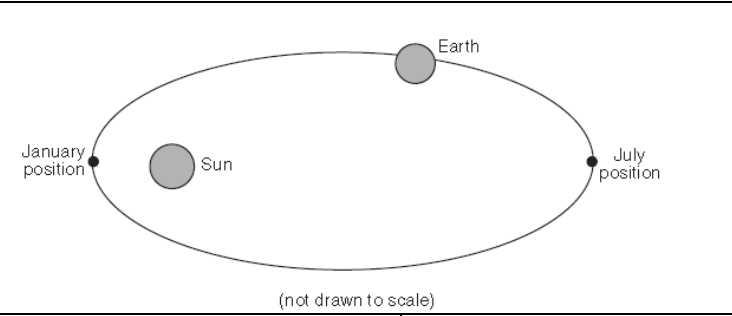
<b>61.</b> The diagram on the right represents the path of Earth around the Sun. As Earth travels in its orbit from its January position to its July position, the potential energy of Earth			
	(a) decreases and its kinetic energy decreases	(b) decreases and its kinetic energy	(c) increases and its kinetic energy decreases

<b>62.</b> A temperature change of 20 Celsius degrees is equal to a temperature change of			
(a) 20. Kelvins	(b) 36. Kelvins	(c) 253 Kelvins	(d) 293 Kelvins

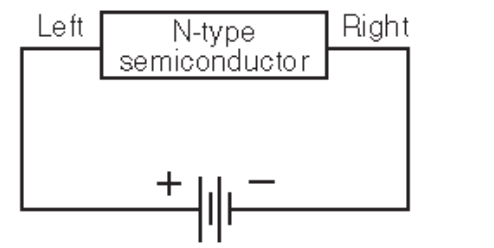
<b>63.</b> The diagram on the right shows a circuit with a battery applying a potential difference across an <i>N</i> -type semiconductor. The majority charge carriers in the semiconductor are			
	(a) negative electrons moving to the right	(b) negative electrons moving to the left	(c) positive holes moving to the right

<b>64.</b> If nitrogen nuclei are bombarded with alpha particles they can be changed into oxygen nuclei. This phenomenon is known as			
(a) nuclear fission	(b) nuclear fusion	(c) artificial transmutation	(d) particle scattering

<b>65.</b> Which device can be used to detect subatomic particles that exit nuclei?			
(a) Van de Graaff generator	(b) Geiger counter	(c) linear accelerator	(d) cyclotron

<b>66.</b> If the nucleus of an atom emits a positron, the atomic number of the atom will			
(a) decrease by one	(b) increase by one	(c) remain unchanged	(d) decrease by two

<b>67.</b> The half-life of a particular radioactive material is 6.0 hours. What fraction of a sample of the material would remain after 1 day?			
(a) 1/4	(b) 2/3	(c) 3/8	(d) 1/16

<b>68.</b> In a working transistor circuit, as the emitter-base current is increased, the collector current	
(a) decreases by a small amount	(b) decreases by a large amount
(c) increases by a small amount	(d) increases by a large amount

<b>69.</b> Spherical aberration is a defect associated with	
(a) spherical mirrors, only	(b) plane mirrors, only
(c) both spherical mirrors and lenses	(d) both plane mirrors and lenses

<b>70.</b> If the current in an ammeter's coil is doubled, the resulting torque on the coil will be	
(a) unchanged	(b) halved
(c) doubled	(d) quadrupled

### Part III: Physics-Descriptive Questions [30 Marks]

**Question No 01:** A rocket of constant mass  $2.00 \times 10^3$  kg, is fired vertically upward with constant acceleration. After one minute it reaches a height of 36.0 km and its engine is switched off. Assuming the rocket's mass and  $g$  remain constant, calculate

- the initial acceleration of the rocket
- the maximum height reached.
- the total time of flight.
- the work done by the rocket.

(2+3+2+3)

**Question No 02:** Fast neutrons, mass  $m_1$ , with a speed  $v_1 = 2.0 \times 10^7$  m/s are slowed down in a nuclear reactor by elastic collision with the nuclei of a moderator.

- Derive the general expression for the speed  $v$  of the neutron after collision with a nucleus of mass  $m_2$  which is initially at rest.
- Calculate the speed  $v$  of a neutron after a single, head on, collision with a Hydrogen nucleus.
- Calculate the speed  $v$  of a neutron after a single, head on, collision with a Carbon nucleus.
- After many collisions with atoms of the moderator at room temperature, what energy will neutron attain?

(4+2+2+2)

The masses involved are neutron: 1.0087 amu, hydrogen nucleus: 1.0073 amu; carbon nucleus: 11.9934 amu.

**Question No 03:** The table below shows measurements of the decay rate of a sample of  $^{128}\text{I}$ , a radionuclide often used medically as a trace to measure the rate at which iodine is absorbed by the thyroid gland.

Time (minutes)	R (counts/s)
4.00	392.2
68.00	65.5
132.00	10.9
196.00	1.86

- Write an expression for the activity of the radionuclide as a function of time.
- What is half-life, and decay constant of the radioactive decay?
- What is the relationship between half-life, and decay constant of the radioactive decay?
- Use above data to find the decay constant and half-life of  $^{128}\text{I}$ .

(2+2+1+5)

---End of paper---